

Parts for Pump Models: SP1600X5, SP1605X7, SP1607X10, SP1608X10, SP1610X15, SP1611X15, SP1615X20, SP1616X20, SP1621X25

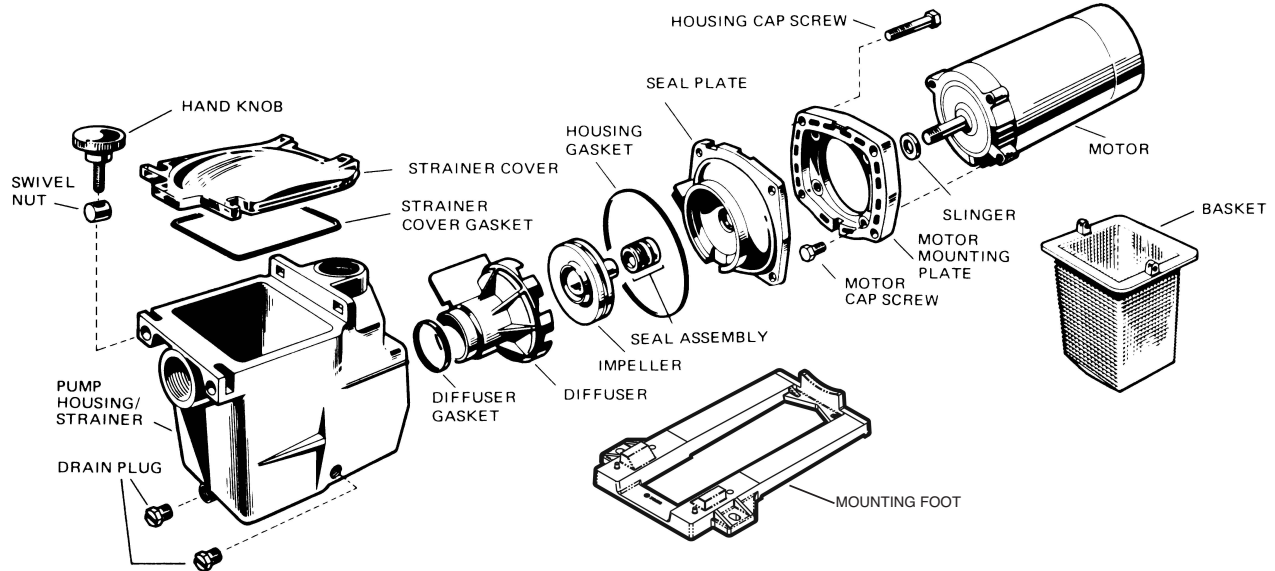

Part No.	Description	Ctn. Qty.
SPX1600AA	Pump Housing/Stainer, 1 1/2" x 1 1/2", with Drain Plugs	1
SPX1620AA	Pump Housing/Stainer, 2" x 2", with Drain Plugs	1
SPX1600T	Housing Gasket	10
SPX1600R	Diffuser Gasket	10
SPX1600TRA	Seal Assembly Kit (Includes Seal Assembly, Housing and Diffuser Gaskets)	10
SPX1600D	Strainer Cover, Clear	10
SPX1600DB	Strainer Cover for Biguanide Sanitizers NOT Pressure Testable	10
SPX1600S	Strainer Cover Gasket	20
SPX1600M	Basket	20
SPX1600PN	Hand Knob Kit (Includes Swivel Nut and Hand Knob)	10
SPX1600V	1/4" Drain Plug (1991 and Prior)	25
SPX1700FG	1/4" Drain Plug with Gasket (1992 and later)	10
SPX2600G1	Mounting Foot with Adapter and Screws	10
SPX1600Z52	Mounting Foot Cap Screw (Set of 2 – 2 Sets Required)	1
SPX1600Z2	Seal Assembly	10
SPX1600F5	Motor Mounting Plate	10
SPX1600Z4	Housing Cap Screw	10
SPX0125Z44	Motor Cap Screw (Set of 4)	1
SPX0125F	Slinger	10

Med. Hd.	High Hd.	Parts listed below must be ordered for specific model and H.P.:	Ctn. Qty.
SPX2600CKIT*	—	1/2 H.P. Drive Train Upgrade	1
SPX2605CKIT*	—	3/4 H.P. Drive Train Upgrade	1
SPX2607CKIT*	—	1 H.P. Drive Train Upgrade	1
SPX2610CKIT*	—	1 1/2 H.P. Drive Train Upgrade	1
SPX2615CKIT*	—	2 H.P. Drive Train Upgrade	1
(All above kits Include Impeller, Diffuser, Seal Plate, Housing Gasket, Diffuser Gasket and Motor Mounting Plate)			
—	SPX1621C	Impeller, for 2 1/2 H.P. Max Rated	1
—	SPX1611E5	Seal Plate 2 1/2 H.P.	10
SPX1600Z1M		Motor, 1/2 H.P., Threaded Shaft (Single Phase, 60 Cycle 115V)	1
SPX1605Z1M		Motor, 3/4 H.P., Threaded Shaft (Single Phase, 60 Cycle 115/230V)	1
SPX1607Z1M		Motor, 1 H.P., Threaded Shaft (Single Phase, 60 Cycle 115/230V)	1
SPX1610Z1M		Motor, 1 1/2 H.P., Threaded Shaft (Single Phase, 60 Cycle 115/230V)	1
SPX1615Z1M		Motor, 2 H.P., Threaded Shaft (Single Phase, 60 Cycle 115/230V)	1
SPX1620Z1M		Motor, 2 1/2 H.P., Threaded Shaft (Single Phase, 60 Cycle 230V)	1

NOTE: For pumps with an "SP1600X—" part number (manufactured before 1983), the use of these new kits (SPX2600CKIT – SPX2615CKIT) will upgrade the old pump to our current "SP2600X—" series. This will improve GPM, reduce noise and provide slightly better energy efficiencies. All individual components included in the kits are not available.



Super Pump®

SP2600X PUMP SERIES (MAX-RATED) REPLACEMENT PARTS

Parts for Pump Models: SP2600X5, SP2605X7, SP2607X10, SP2607EE, SP2610X15, SP2615X20, SP2621X25

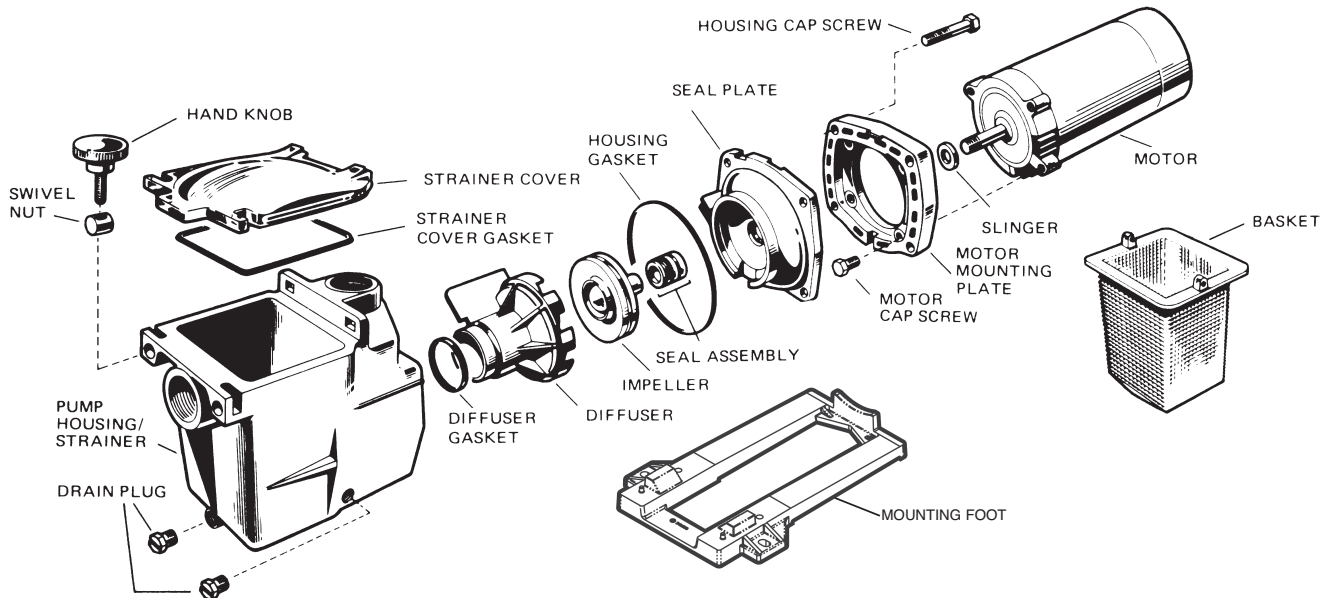

Part No.	Description	Ctn. Qty.
SPX1600AA	Pump Housing/Strainer, 1 1/2" x 1 1/2", with Drain Plugs	1
SPX1620AA	Pump Housing/Strainer, 2" x 2", with Drain Plugs	1
SPX1600T	Housing Gasket	10
SPX1600R	Diffuser Gasket	10
SPX1600TRA	Seal Assembly Kit (Includes Seal Assembly, Housing and Diffuser Gaskets)	10
SPX1600D	Strainer Cover, Clear	10
SPX1600DB	Strainer Cover for Biguanide Sanitizers NOT Pressure Testable	10
SPX1600S	Strainer Cover Gasket	20
SPX1600M	Basket	20
SPX1600PN	Hand Knob Kit (Includes Swivel Nut and Hand Knob)	10
SPX1600V	1/4" Drain Plug (1991 and Prior)	25
SPX1700FG	1/4" Drain Plug with Gasket (1992 and later)	10
SPX2600G1	Mounting Foot with Adapter and Screws	10
SPX1600Z52	Mounting Foot Cap Screw (Set of 2 – 1995 and Prior, 2 sets required)	1
SPX1600Z2	Seal Assembly	10
SPX1600F5	Motor Mounting Plate	10
SPX1600Z4	Housing Cap Screw	10
SPX0125Z44	Motor Cap Screw (Set of 4)	1
SPX0125F	Slinger	10
SPX2600B	Diffuser, for 1/2 thru 2 H.P.	1
SPX1616B	Diffuser, for 2 1/2 H.P. only	1
SPX2600E5	Seal Plate, 1/2 thru 2 H.P.	10
SPX1611E5	Seal Plate, for 2 1/2 H.P. only	10

Parts listed below must be ordered for specific model and H.P.:

SPX2600C	Impeller, for 1/2 H.P.	10
SPX2605C	Impeller, for 3/4 H.P.	10
SPX2607C	Impeller, for 1 H.P.	10
SPX2610C	Impeller, for 1 1/2 H.P.	10
SPX2615C	Impeller, for 2 H.P.	1
SPX1621C	Impeller, for 2 1/2 H.P.	1
SPX1600Z1M	Motor, 1/2 H.P., Threaded Shaft (Single Phase, 60 Cycle 115V)	1
SPX1605Z1M	Motor, 3/4 H.P., Threaded Shaft (Single Phase, 60 Cycle 115/230V)	1
SPX1607Z1BECAG	Motor, 3/4 H.P., Energy Efficient, Threaded Shaft (Single Phase, 60 Cycle 115/230V)	1
SPX1607Z1M	Motor, 1 H.P., Threaded Shaft (Single Phase, 60 Cycle 115/230V)	1
SPX1610Z1M	Motor, 1 1/2 H.P., Threaded Shaft (Single Phase, 60 Cycle 115/230V)	1
SPX1615Z1M	Motor, 2 H.P., Threaded Shaft (Single Phase, 60 Cycle 115/230V)	1
SPX1620Z1M	Motor, 2 1/2 H.P., Threaded Shaft (Single Phase, 60 Cycle 230V)	1
SPX1607Z2MS	Motor, 1 H.P., Threaded Shaft, 2-Speed (Single Phase, 60 Cycle 230V)	1
SPX1610Z2MS	Motor, 1 1/2 H.P., Threaded Shaft, 2-Speed (Single Phase, 60 Cycle 230V)	1
SPX1615Z2MS	Motor, 2 H.P., Threaded Shaft, 2-Speed (Single Phase, 60 Cycle 230V)	1