

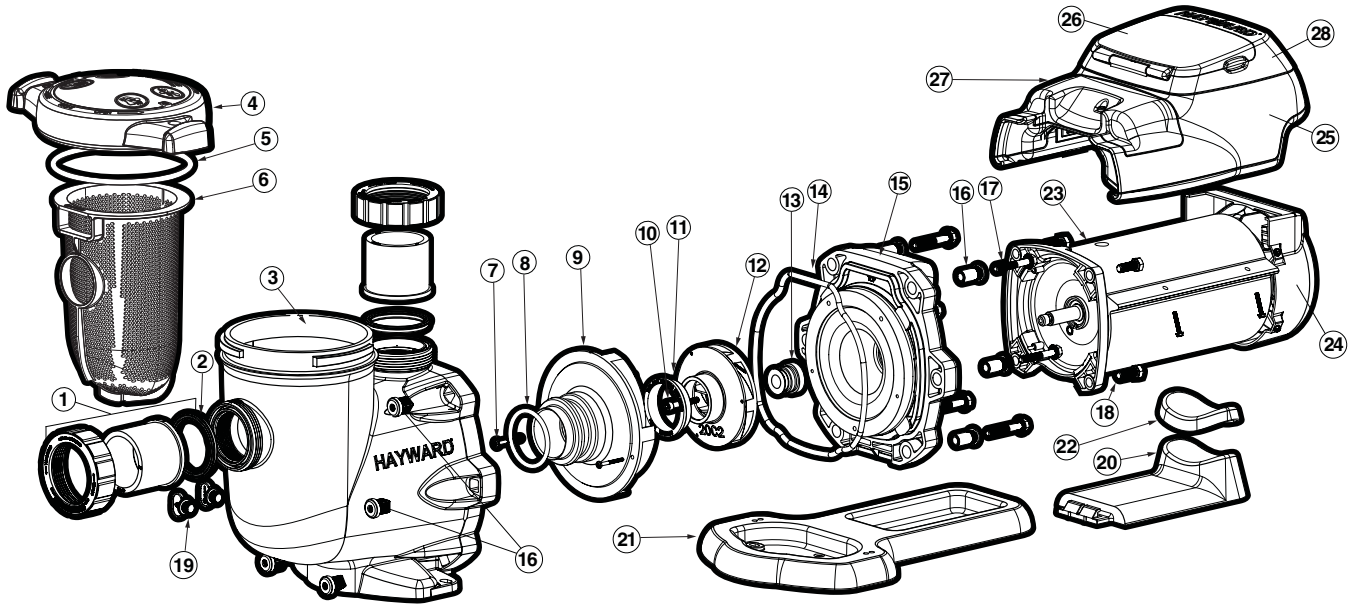

# EcoStar®

## SP3400VSP PUMP SERIES REPLACEMENT PARTS

Parts for Pump Models: SP3400VSP, SP3400VSPVR



Ref. No.	Part No.	Description	Ctn. Qty.
1	SPX3200UNKIT	Union Connector Kit (Includes Union Nut, Union Connector, Union Gasket – 2 ea.)	1
2	SPX3200UG	Union Gasket	1
3	SPX3200A	Pump Strainer Housing, 2" x 2 1/2" with Drain Plugs, Threaded Style	1
4	SPX3200DLS	Strainer Cover Kit (Includes Strainer Cover, Lock Ring, O-Ring)	10
	SPX3200DLSB	Strainer Cover Kit (Biguanide Sanitizer Applications Only; NOT Pressure Testable)	10
5	SPX3200S	Strainer Cover O-Ring	10
6	SPX3200M	Strainer Basket	15
7	SPX3200Z8	Diffuser Screw	1
8	SPX4000Z1	Diffuser O-Ring	10
9	SPX3200B3	Diffuser	1
10	SPX3200Z1	Impeller Screw	1
11	SPX3021R	Impeller Ring	1
12	SPX3220C	Impeller with Impeller Screw	10
13	SPX3200SA	Shaft Seal Assembly	10
14	SPX3200T	Housing O-Ring	10
15	SPX3200E	Seal Plate	1
16	SPX3200Z211	Housing Insert/Seal Plate Spacer Kit	1
17	SPX3200Z3	Housing Bolt	10
18	SPX3200Z5	Motor Bolt	1
19	SPX4000FG	Drain Plug with O-Ring	10
20	SPX3200GA	Bracket, Motor Support	1
21	SPX3200WF	Riser Base Aligns with Pentair® WhisperFlo® Ports	1
22	SPX3200Q	Adapter-Motor Support	100
23	SPX3400Z1ECM	Motor Assembly	1
24	SPX3400FAN	Motor Fan Shroud	5
25	SPX3400DR	Motor Drive (Includes Digital Control Interface)	1
	SPX3400DRVR	Motor Drive, SVRS (Includes Digital Control Interface)	1
26	SPX3400DR4	Motor Drive Display Cover	5
27	SPX3400DR2	Motor Drive Wiring Cover	5
28	SPX3400LCD	Digital Control Interface Assembly	1
—	SPX3400DRKIT	Wall Mount Kit	5

Pumps